



# EK ENGINEERING

## WHO WE ARE

EK Engineering was established in 2016 by Electrical Engineer from IIT-BHU. It started with vision to design, manufacture products for human and plant safety & control automation. Slowly, over the years, the organization transformed itself into reliable and fastest growing manufacturer and supplier for multi-diversified product and systems for detection and controls in commercial and industrial application.

EK Engineering is an ISO 9001:2015 certified organization and operates under following division umbrella:



### MANUFACTURING DIVISION

- Gas & Flame detection and control system
- Electrical and automation control panels
- Parking management and guidance systems



### PROJECT DIVISION

- Gas detection, control and automation system in commercial and industrial segment incl. automobile, oil & gas etc.
- Building & industrial ventilation
- Parking management, guidance and booking system



### EXPORT DIVISION

- Deals in supply of products and equipment related to
- HVAC, MEP, building construction
  - Safety and security
  - Engineering goods



# INDUSTRIES WE SERVE



- Industries
- Residential Apartments
- Malls
- Corporate Offices
- Grocery Stores
- Hotels
- Hospitals
- Oil & Gas Field
- An More...







# Manufacturing

At EK Engineering, we deploy our expertise in manufacturing of high accuracy, reliable and industrial grade instrumentation and control systems, through our brand "SmartSensor".

We, also design and manufacture as per application and customer requirement for OEM purpose.

We follow strict process and guidelines in all our manufacturing process, right from raw material and component procurement to testing and dispatch. Our Company is an ISO 9001: 2015 for quality control. Our Products are CE complied.

## Our Manufacturing product line includes:

- Toxic, flammable, oxygen gas detectors
- Electrical & Control Panel – PLC, VFD, DDC Panels
- Process and BMS instrumentation
- Parking detection, guidance and booking system

Our products and systems find application in all industrial and commercial segments including oil & gas, power, mining, chemical, pharmaceuticals, building, warehouse, food processing and so on.

We also design, manufacture and integrate complete system

- Gas & Flame Detection and control / alarm system for commercial and industrial projects.
- Vehicle parking detection, guidance, fee collection and online booking system
- Underground / basement / Industrial ventilation and automation system
- Process control & automation system





**EK Engineering**  
Solutions and more...

# Gas Detection

Toxic, Flammable Gases

## Our gas detectors are designed for:

- All toxic gases including CO, CO<sub>2</sub>, H<sub>2</sub>S, Ammonia, Freons etc.
- All flammable / explosive gases including methane, VOC, LPG etc.
- Oxygen and inert gases

## Features:

- Jumper selectable analog output (0-10V / 4-20mA)
- LCD Display, on-board relays
- RS485 Modbus RTU digital communication
- UL listed sensor
- BMS / SCADA / PLC integration compatibility.



# Sensors / Instrumentation



**EK Engineering**  
Solutions and more...

## **Sensor transmitter, switch parameters:**

- Differential pressure
- Pressure
- Temperature
- Humidity
- Flow switch

## **Instrument type / output includes:**

- Transmitter output / RS485  
Modbus compatible
- Switch output
- Gauges





# Automation & Electrical Panel

PLC, VFD, MCC, PCC, BMS



**EK Engineering**  
Solutions and more...

## **Control panels, independent or combination**

- PLC / DDC Panels
- VFD / VSD Panels
- MCC (LT / HT) Panels
- BMS System

## **Test Outward Panel**

- HT / LT power supply
- Earth faults
- Overvoltage
- Insulation / Resistance test

We manufacture panels following applicable electrical and control standard with state-of-art CNC machine, durable powder coating process.



# AIR VENTILATION & CONDITIONING



**EK Engineering**  
Solutions and more...

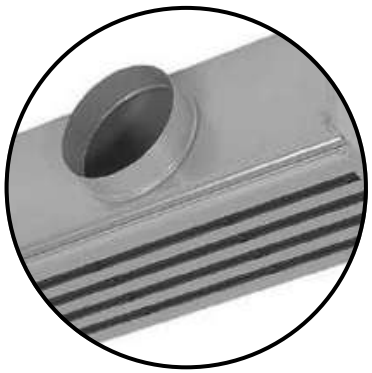
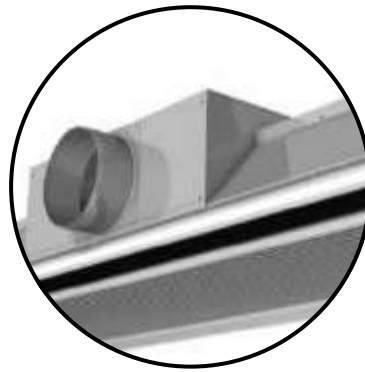



# AIR VENTILATION & CONDITIONING



**EK Engineering**  
Solutions and more...

- **Axial Fans/ Blower**
- **Bag Filters**
- **Industrial Fans**
- **High Temperature Fans**
- **ADP Products**
- **Air Purifier**
- **Blower Coils**
- **Jet Fans**
- **HVLS Fans**
- **Pre-Fabricated Ducts**
- **Access Doors / Panels**
- **Cabinet Fans**
- **Expansion Valves**
- **Fire & Smoke Dampers**
- **Fume Hoods**
- **Fan Coil Units**
- **Centrifugal Fans**
- **Fan Filter Unit**
- **Inline Fans**
- **Heat Exchanger**
- **Air Curtains**
- **VAV Diffusers**
- **Fan Section**
- **Scrubbers**
- **Tunnel Dampers**





# AIR-CONDITIONING & REFRIGERATION



**EK Engineering**  
Solutions and more...

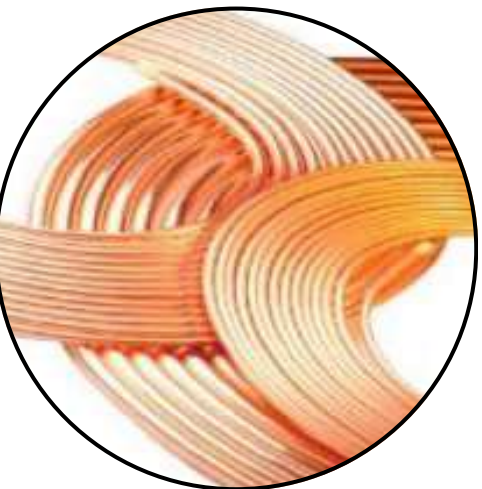
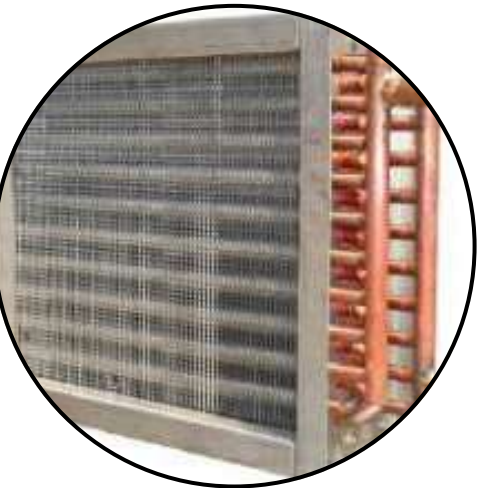

# AIR-CONDITIONING & REFRIGERATION



**EK Engineering**  
Solutions and more...

- **VRF / VRV / Chillers**
- **Air-conditioners & Accessories**
- **Evaporative Air Coolers – direct, indirect**
- **Air Washer**
- **Air Scrubbers**
- **Heat recovery system**
- **Cold Rooms**
- **Blast Freezers**
- **Access Panels**
- **Insulation – Acoustic, Thermal**
- **Chilled Beam**
- **Air Handling Units**
- **VAV Diffusers**
- **AHU/ FCU / TFA**
- **Tubes & Elbows**
- **Valves & Actuator**
- **Refrigerators**
- **Expansion Valves**
- **Humidifier**
- **Strainer**





# ELECTRICAL EQUIPMENTS



**EK Engineering**  
Solutions and more...

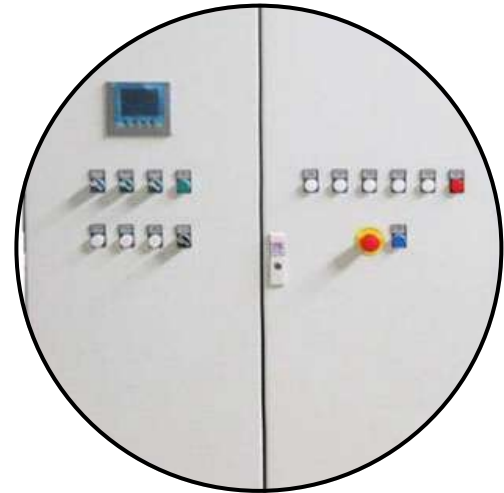

- HT / LT Panels
- Variable Frequency Drives
- MCC / PCC Panels
- PLC Panels
- BMS / SCADA VFD Panels
- Electrical Switchgears
- Generators
- Lights & Fittings
- Pump & Motors
- Measuring & Testing Meters
- Electrical & Control Cable



- Transformer
- Automation System
- Electric & Pneumatic Actuator
- Energy Meter

# SAFETY & SECURITY



**EK Engineering**  
Solutions and more...



- **Toxic and Flammable Gas**
- **Gas Control Panels**
- **Air Quality**
- **Flame detectors**
- **Fire Alarm system**
- **Alarm Accessories**
- **PPE Instruments**
- **Fire System**
- **Accessories**
- **Fire Panels**
- **Fire Pumps**
- **Scrubbers / Absorption**
- **Cartridges Filters**



# INDUSTRIAL & AUTOMATION SYSTEM



**EK Engineering**  
Solutions and more...



- **Pressure / Differential**
- **pH / TDS / EC**
- **Air Quality**
- **Flow**
- **Velocity**
- **Humidity**
- **Temperature**
- **Energy**
- **Density**
- **Level**
- **Weather**
- **Motion**



**EK Engineering**  
Solutions and more...

# ENGINEERING PRODUCTS / SYSTEMS



- **Engineering Goods**
- **Regulator**
- **Metal Sheets & Pipes**
- **Air Separator**
- **Doors / Barriers**
- **Bush & Bearings**
- **Control Valves**
- **Reducers**
- **Fork Lifts**
- **Elbows & Fittings**
- **Hand & Power Tools**
- **Nozzles**
- **Seals & Gaskets**
- **Wire & Cables**
- **Tanks**
- **Nut & Bolts**





# Merchant Trade Division



**EK Engineering**  
Solutions and more...

With our merchant trade & export division, we deal in export and trade for products and equipment used in following areas:

- Air ventilation and distribution products
- Air-conditioning equipment and accessories
- Engineering goods for industrial, building construction, material movement etc.
- Mechanical products, equipment, machineries
- Electrical equipment, Panels and accessories
- Process and climate control products
- Control, Automation products and switchgears
- Metal, pipes and allied products
- Safety and security products E.g. Fire, personal protection etc.
- Special machinery and products

We supply products and equipment to domestic client all over India, as well as to international buyers from African, Middle East, Far East Asia, Latin American, Caribbean, European countries.



# Industrial & Building Ventilation & Automation System



**EK Engineering**  
Solutions and more...

Apart from undertaking EPC projects for gas & flame detection & control system, we also design, execute projects and system for industrial and commercial ventilation including underground car parks, factory / process facility ventilation, toxic air filtration / suppression system.

Projects includes right from ventilation conceptualization, design, fabrication, integration to testing and commissioning. We have successfully executed various projects including for smart cities, chemical plants, warehouses, commercial building, malls / shopping complex, theatre / multiplex etc.

These systems are completely automated, without manual intervention, reliable, Energy efficient and demand controlled based on various climate / health / defined parameters.

Ventilation system design includes both ducted and ductless system, with feedback control mechanism.

# Building Management System



**EK Engineering**  
Solutions and more...

Our BMS helps meet the comfort and safety needs of your occupants while also increasing your operational and energy efficiency through a full range of HVAC, energy, lighting, air quality, gas detection, and smoke management solutions. The single coordinated view of these systems, and their synchronized response, promotes a safer and more energy efficient building every day and better response in the event of an emergency.

**BMS Features:** Alarm Management, Time Scheduling, Event Recording

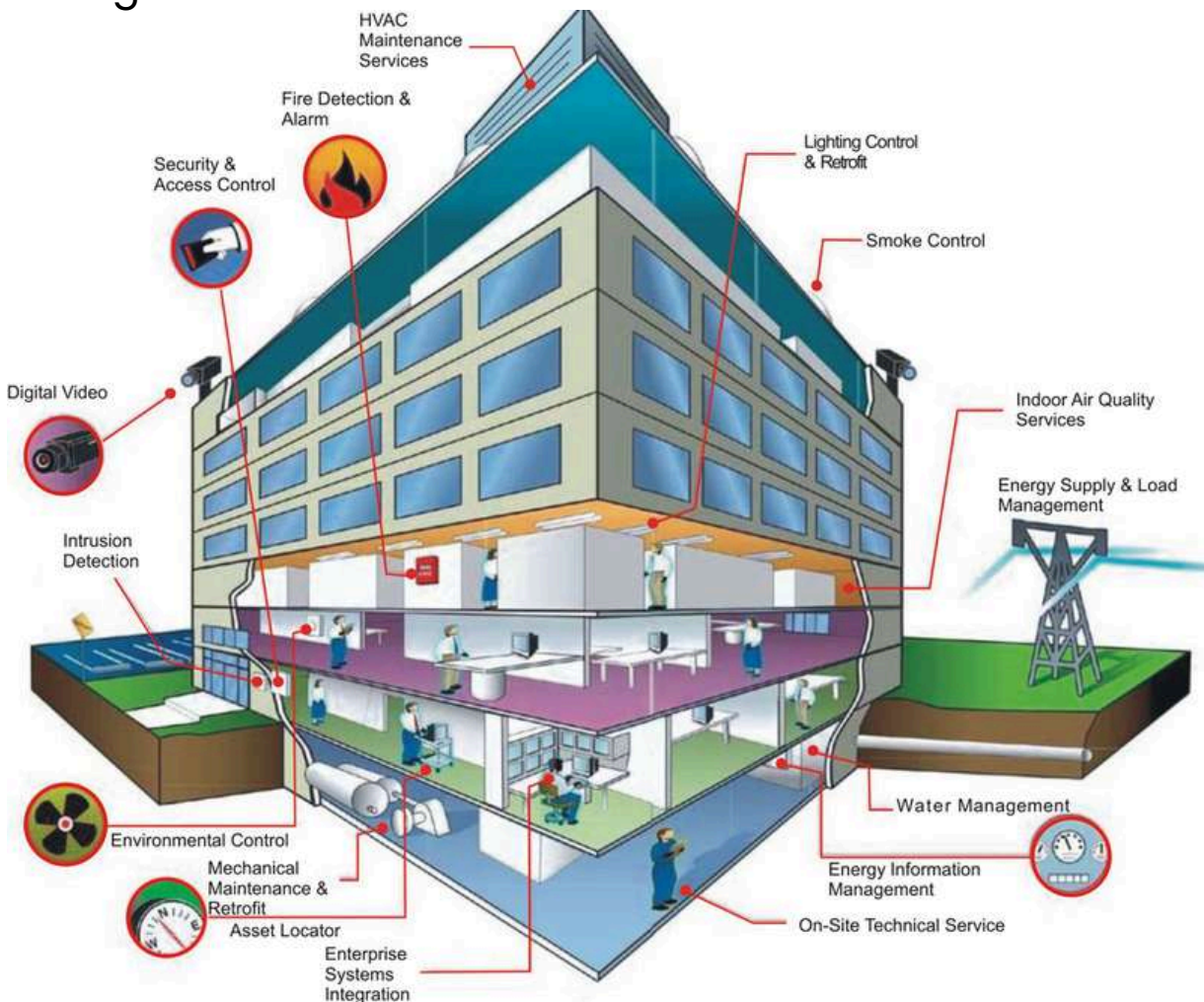



# Our Principals



**EK Engineering**  
Solutions and more...

## TELEFIRE

Fire Safety, Building Management & Security

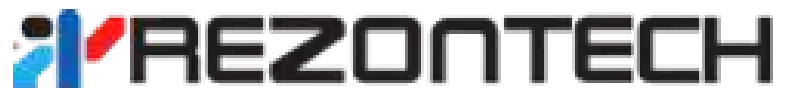

Flam Detector, Sensors, Gas Detector, Test  
Equipment



AMCA, UL listed – Axial Fans, Jet Fans, Fire damper, marine dampers, air damper, smoke damper, tunnel damper, centrifugal fans, kitchen & lab ventilation products, gravity ventilators



Concentration meter, oxygen sensor, CO<sub>2</sub>, sugar meter, process  
system / SKIDs

# Our Clients



**EK Engineering**  
Solutions and more...

**Bloomberg**

**Honeywell**  
THE POWER OF CONNECTED

**SIEMENS**





**EK Engineering**  
Solutions and more...

# Countries We Serve



- Bahrain
- Brazil
- Bangladesh
- China
- Cambodia
- Fiji
- Gambia
- Ghana
- Iraq
- India
- Iran
- Kuwait
- Macaw
- Mauritian
- Myanmar
- Malaysia
- Malta
- Nepal
- Peru
- Poland
- South Africa
- South Arabia
- Shri Lanka
- Thailand
- UAE
- USA
- Tanzania



# Our Certification



**EK Engineering**  
Solutions and more...



## Registration Certificate

This is to certify that

### EK ENGINEERING

NEAR VYAS PUBLIC SCHOOL, PURANI GINANI, OPPOSITE POLICE LINE, BIKANER - 334001,  
RAJASTHAN, INDIA.

Has been assessed by RAPL and found to comply with the requirements of

## ISO 9001 : 2015 Quality Management Systems

For the following activities:

SUPPLY / EXPORT, INSTALLATION, TESTING AND COMMISSIONING OF GAS & FIRE  
DETECTION SYSTEM, HVAC, SAFETY, SECURITY, PROCESS PLANTS &  
EQUIPMENTS, INSTRUMENTATION, AUTOMATION  
& ELECTRICAL PANELS.

Certificate Number: E2024049769  
Date of certification: 19/04/2024  
1st Surveillance on or before: 18/04/2025  
IInd Surveillance on or before: 18/04/2026  
Certification Valid Until: 18/04/2027



Accredited  
QMS Certification CAB# 119012

Director (Certification)  
**Royal Assessments Pvt. Ltd.**

E20, A, Tower-B, (Thurs, Plot No. A-40, Sector - 82, Noida- 201301, India.  
www.royalapl.com, info@royalapl.com  
Phone: +91 120 4251329

This Certificate can be verified at [www.royalapl.com](http://www.royalapl.com)

*This Certificate remains the property of Royal Assessments Private Limited. Must be returned on request or if certificate is withdrawn. Validity of this certificate is subject to successful surveillance audits. RAPL is accredited by EGAC. EGAC is member of International Accreditation Forum (IAF) and signatory of NCA.*



**EK ENGINEERING**  
MANUFACTURE | PROJECTS | TRADE

# CONTACT US



## EK ENGINEERING



HQ: NEAR VYAS PUBLIC SCHOOL, PURANI  
GINANI BIKANER (INDIA) ZIP CODE 334001



### EMAIL:

india.eke@gmail.com  
contact1@ekeindia.com



### WEBSITE:

<https://ekeindia.com>



### CONTACT

+91-96809 66000  
(INDIA)



+91-96809 66000 (INDIA)



<http://www.linkedin.com/in/ekeindia>